

MUM

LIFT M2 ZERO GRAVITY

Code PR07620



DESIGN IN MOVIMENTO

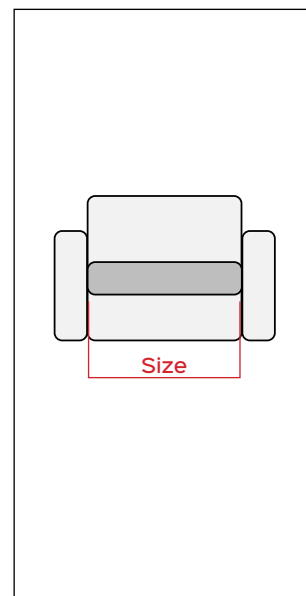

Motorized	27kg +/- 1kg	Armchair	MAX 120kg 270lbs Maximum lifting capacity	Cycles: 30.000	2 YEARS Mechanism 2 YEARS Actuator Warranty
-----------	--------------	----------	--	----------------	---

Standard sizes (mm)
520

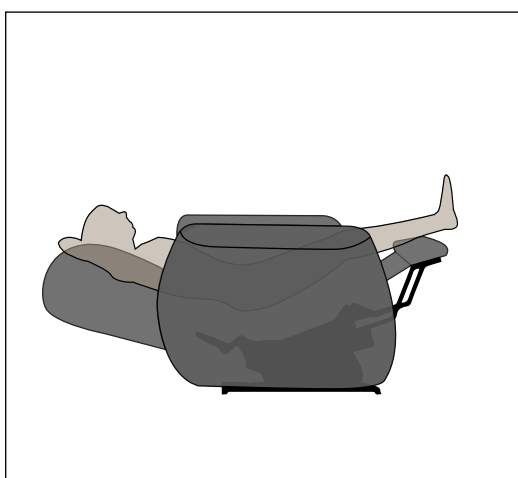

Positions:

Closed TV Full Relax Zero Gravity Lift

Benefit: Entry level mechanism of the Lift family designed to ensure high lifting performance and comfort, facilitating the daily life of the most needy user. Two actuators regulate the different movements in order to ensure infinite use positions, from closed to TV to full relax to lifting (lift) up to zero gravity

position. An actuator has the function of extending the footboard and plays a light tilting action of seat and back; the second, instead, reclines the backrest until it reaches the opening position. Various options are available and give the final customer the opportunity to have a product customized according to their needs.

Optional

SOME ACCESSORIES	CARTER	HEADREST & RATCHETS
	KD	TROLLEY KIT

ELECTRIC KIT	ACTUATORS
	PLUGS & CABLE EXTENSIONS

CONTROL SYSTEM	BUILT IN SWITCHES	CONTROL PLATES
	TOUCH SENSOR	WIRED/ WIRELESS REMOTES