

# LEVANTE

CLASSIC STD M2

Code PE07359-IT-GP

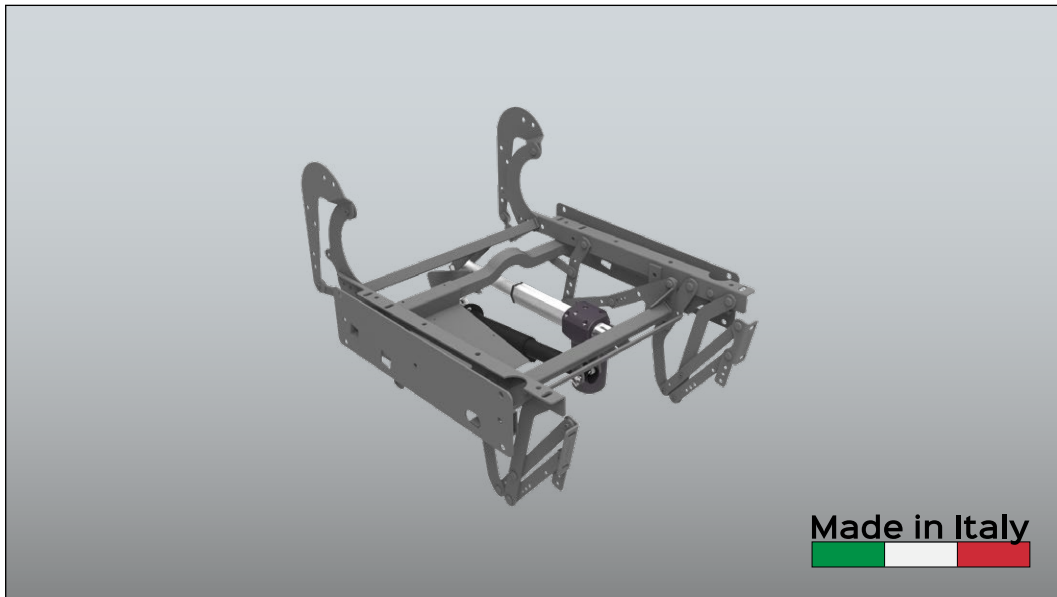

Made in Italy

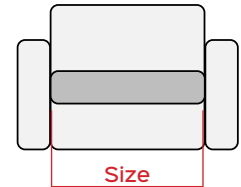

Standard sizes (mm)
520

Motorized	15kg+/-1 kg	Armchair	MAX 170kg 380lbs Maximum capacity	Cycles:30.000	2YEARS Mechanism 2YEARS Actuator Warranty
-----------	-------------	----------	---	---------------	---

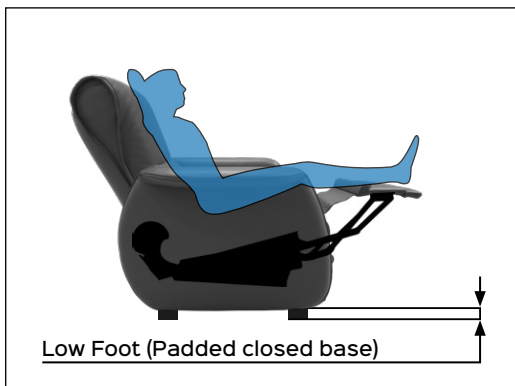

Positions:



Closed



TV



Full Relax

**Benefit:** The KEYMOTION mechanisms are built entirely in Italy, from the raw material, to the processing, up to the final assembly and testing. The products are carefully checked before being shipped. This mechanism is designed to ensure high lifting performance and comfort, facilitating the everyday life of the most needy user. Two motors regulate the different

positions: closed, TV and full relax. The first actuator extends the footboard by doing a slight tilting action to the seat and backrest; the second actuator instead reclines the backrest until you reach the Full Relax position. LEVANTE CLASSIC STD M2 has been designed to create padded CLOSED BASE (low foot).

## Optional

SOME ACCESSORIES	HEADREST & RATCHETS	DOUBLE FOOTBOARD	ELECTRIC KIT	ACTUATORS	CONTROL SYSTEM	BUILT IN SWITCHES	CONTROL PLATES		
	CARTER	FINISHES		SEAT AND FOOTREST FRAME		PLUGS & CABLE EXTENSIONS	POWER SUPPLY & BATTERY PACKS	TOUCH SENSOR	WIRED/WIRELESS REMOTES
	DORSAL	KINETIC		ARMREST		CONNECTOR	SMARTPHONE CONTROL SYSTEM		

# LEVANTE

RELAX BED M2

Code PE07780-IT-GP

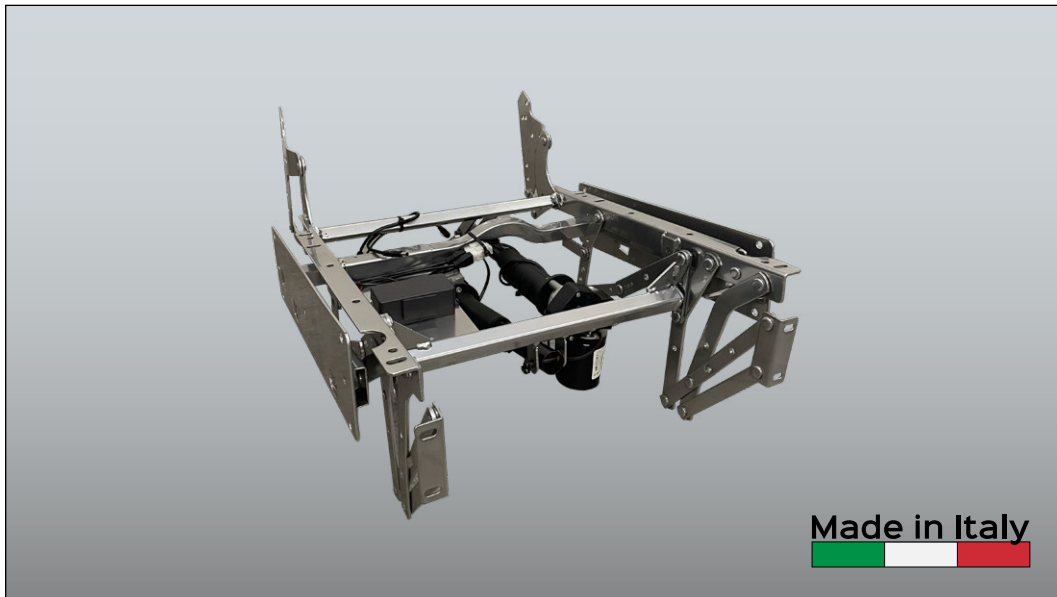

Made in Italy

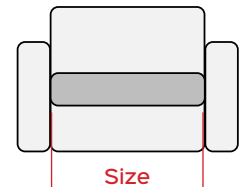

Standard sizes (mm)
520

Motorized	16kg+/-1 kg	Armchair	MAX 170kg 380lbs Maximum capacity	Cycles:30.000	2YEARS Mechanism 2YEARS Actuator Warranty
-----------	-------------	----------	---	---------------	---

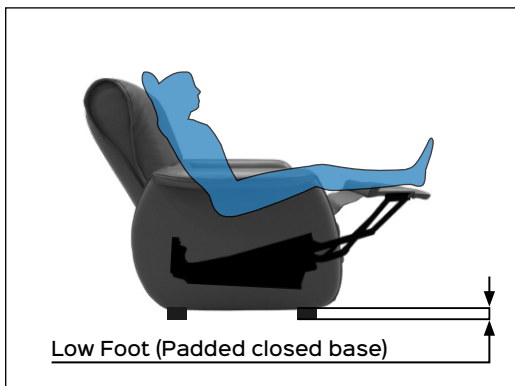

Positions:



Closed



TV



Bed

**Benefit:** The KEYMOTION mechanisms are built entirely in Italy, from the raw material, to the processing, up to the final assembly and testing. The products are carefully checked before being shipped. This mechanism is designed to ensure high lifting performance and comfort, facilitating the everyday life of the most needy user. Two motors regulate the different positions: closed, TV and bed. The first actuator extends the

footboard by doing a slight tilting action to the seat and backrest; the second actuator instead reclines the backrest until you reach the Bed position. Finally, the Bed backrest increases the comfort in the open position with an inclination of as much as 22° more than the standard version. LEVANTE RELAX BED M2 has been designed to create padded CLOSED BASE (low foot).

## Optional

SOME ACCESSORIES	HEADREST & RATCHETS	DOUBLE FOOTBOARD	ELECTRIC KIT	ACTUATORS	CONTROL SYSTEM	BUILT IN SWITCHES	CONTROL PLATES		
	CARTER	FINISHES		SEAT AND FOOTREST FRAME		PLUGS & CABLE EXTENSIONS	POWER SUPPLY & BATTERY PACKS	TOUCH SENSOR	WIRED/ WIRELESS REMOTES
	DORSAL	KINETIC		ARMREST		CONNECTOR	SMARTPHONE CONTROL SYSTEM		

# LEVANTE

RELAX CLASSIC STD XXL M2

Code PE07785-IT-GP

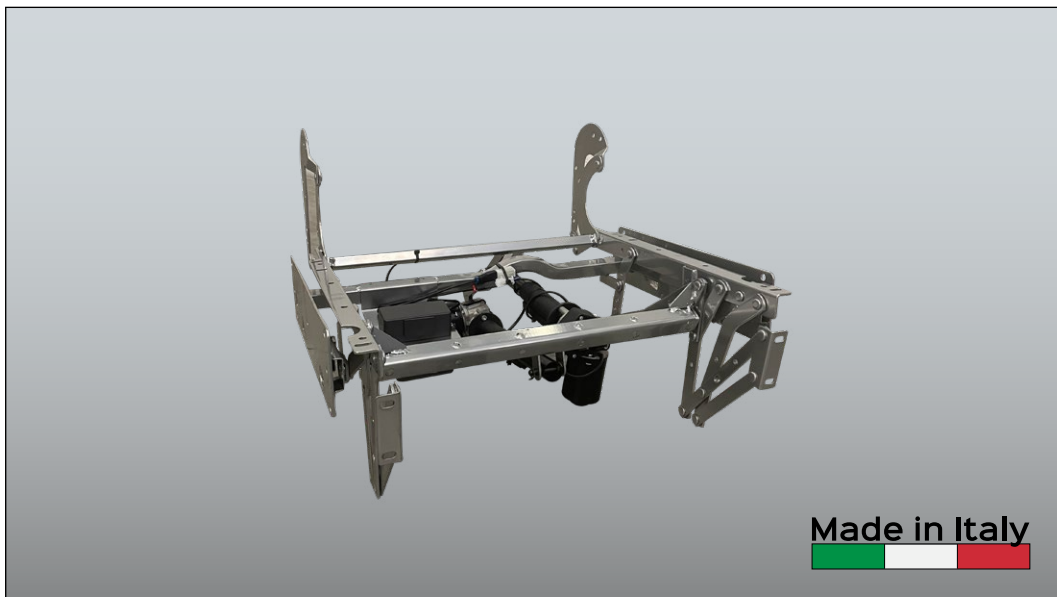

Made in Italy

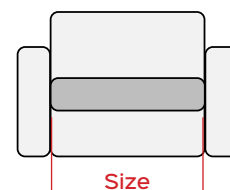

Standard sizes (mm)

630

 Motorized	 18kg+/-1 kg	 Armchair	 MAX 170kg 380lbs Maximum capacity	 Cycles:30.000	 2YEARS Mechanism 2YEARS Actuator Warranty
--	--	---	---	--	---

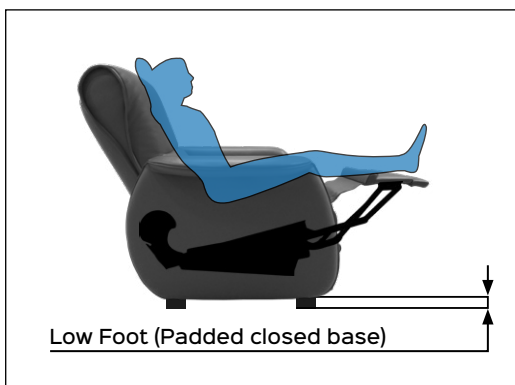

Positions:



Closed



TV













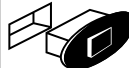



Full Relax

**Benefit:** The KEYMOTION mechanisms are built entirely in Italy, from the raw material, to the processing, up to the final assembly and testing. The products are carefully checked before being shipped. This mechanism is designed to ensure high lifting performance and comfort, facilitating the everyday life of the most needy user. Two motors regulate the different positions: closed,

TV and full relax. The first actuator extends the footboard by doing a slight tilting action to the seat and backrest; the second actuator instead reclines the backrest until you reach the Full Relax position. Thanks to the characteristic "XXL" this mechanism, unlike the homonymous, is equipped with a wider seat vacuum. LEVANTE RELAX CLASSIC STD XXL M2 has been designed to create padded CLOSED BASE (low foot).

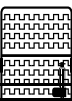
## Optional

<b>SOME ACCESSORIES</b>	 HEADREST & RATCHETS	 DOUBLE FOOTBOARD	<b>ELECTRIC KIT</b>	 ACTUATORS	<b>CONTROL SYSTEM</b>	 BUILT IN SWITCHES	 CONTROL PLATES
 CARTER	 FINISHES	 ARMREST	 PLUGS & CABLE EXTENSIONS	 POWER SUPPLY & BATTERY PACKS	 TOUCH SENSOR	 WIRED/WIRELESS REMOTES	 SMARTPHONE CONTROL SYSTEM
 DORSAL			 CONNECTOR				

# LEVANTE

MACY CLASSIC STD LIFT M3

Code PL06308-XX-GP

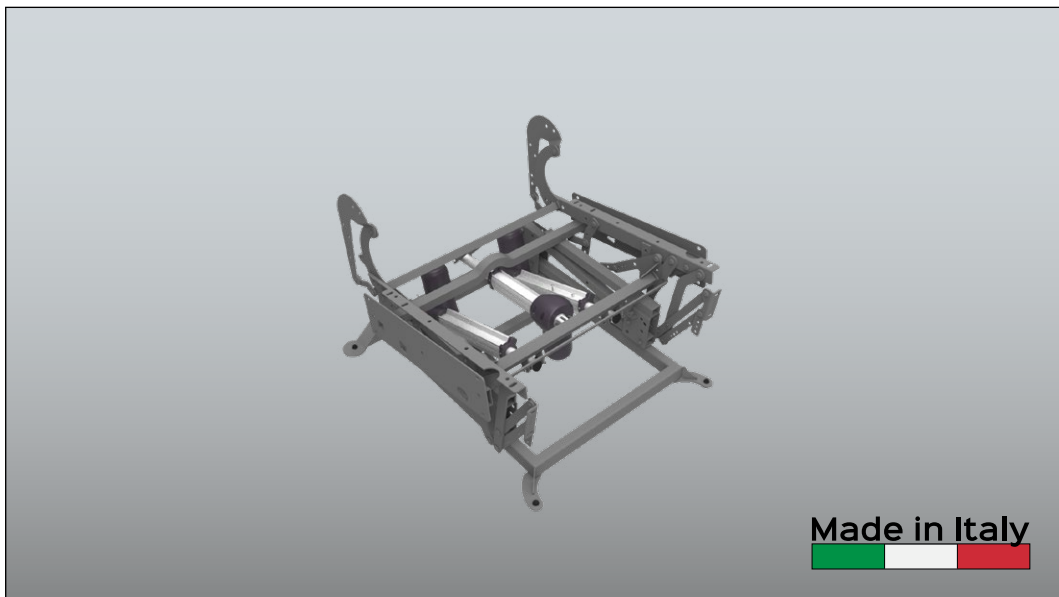

Made in Italy

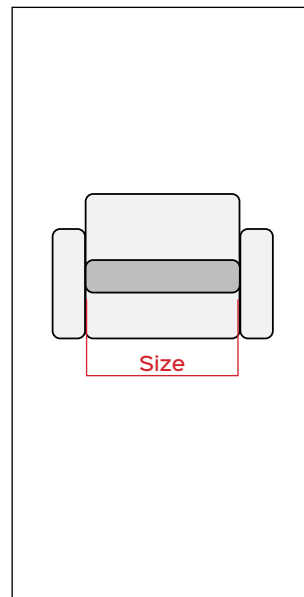

Standard sizes (mm)

630

Motorized	30kg+/-1kg	Armchair	MAX 280kg 620lbs Maximum lifting capacity	Cycles:30.000	2YEARS Mechanism 2YEARS Actuator Warranty
-----------	------------	----------	--	---------------	---

Positions:

Closed

TV

Full Relax

Lift

**Benefit:** The KEYMOTION mechanisms are built entirely in Italy, from the raw material, to the processing, up to the final assembly and testing. The products are carefully checked before being shipped. This mechanism is designed to ensure high lifting performance and comfort, facilitating the everyday life of the most needy user. Three motors regulate the different positions: closed,

TV, full relax and lift. The first actuator and the second, extend the footboard by doing a slight tilting action to the seat and backrest, finally lift the padded up to the Lift position. The third actuator reclines the backrest until it reaches the Full Relax position. The lift system lifts the padded (from Closed position) allowing the person to stand upright. The mechanism is equipped with a base.

## Optional

SOME ACCESSORIES	TROLLEY KIT	HEADREST & RATCHETS	HANDLE	ELECTRIC KIT	ACTUATORS	CONTROL SYSTEM	BUILT IN SWITCHES	CONTROL PLATES			
	CARTER	FINISHES	DOUBLE FOOTBOARD		ARMREST		PLUGS & CABLE EXTENSIONS	POWER SUPPLY & BATTERY PACKS	TOUCH SENSOR	WIRED/ WIRELESS REMOTES	SMARTPHONE CONTROL SYSTEM
	ARMREST KIT	DORSAL					CONNECTOR				

**Keymotion by motionitalia** Design and quality Made in Italy

Business Unit Lucrezia: Via Enzo Ferrari 7, 61030 Lucrezia (PU) Tel. +39 0721 170 74 54 [www.key-motion.it](http://www.key-motion.it)  
 Headquarters: via Navicella 26, 47122 Forlì (FC) Tel.+39 0543 774768 Fax.+39 0543 798409 [www.motionitalia.com](http://www.motionitalia.com) [info@motionitalia.com](mailto:info@motionitalia.com)

The producer reserves the right to modify, at any moment and without notice, the technical specification of its products

# LEVANTE

BED CLASSIC VERTICAL LIFT EXTENDED M2

Code PL07075-XX-GP

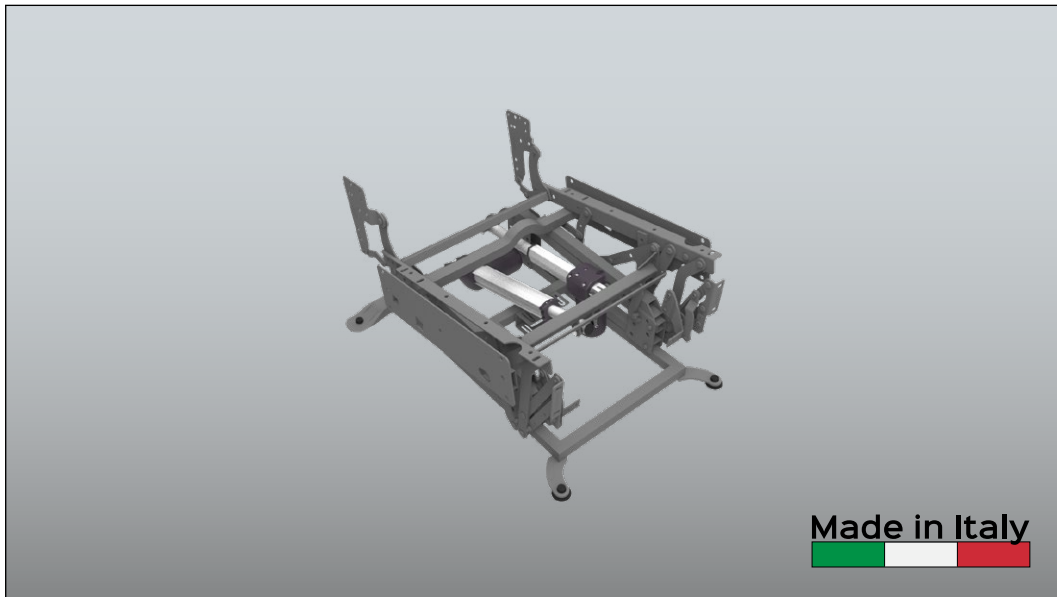

Made in Italy

Motorized	26kg +/- 1kg	Armchair	MAX 170kg 380lbs Maximum lifting capacity	Cycles: 30.000	2 YEARS Mechanism 2 YEARS Actuator Warranty
-----------	--------------	----------	--	----------------	--

Size
Standard sizes (mm)
520

Positions:

Closed

TV

Bed

Lift

**Benefit:** The KEYMOTION mechanisms are built entirely in Italy, from the raw material, to the processing, up to the final assembly and testing. The products are carefully checked before being shipped. This mechanism is equipped with a flap that increases the extension of the footboard (improving comfort), in TV and Full Relax positions. Two motors regulate the different positions: closed, TV, bed and lift. The first actuator, in addition to bringing the padded in

position Lift, extends the footboard by doing a slight tilting action to the seat and backrest; the second actuator instead reclines the backrest until you reach the Bed position. The vertical-lift system raises the padding without rotation for the first 10 cm, allowing the person to adapt to intermediate heights before standing. Finally, the Bed backrest increases the comfort in the open position with an inclination of as much as 22° more than the standard version. The mechanism is equipped with a base.

## Optional

<b>SOME ACCESSORIES</b>	TROLLEY KIT	HEADREST & RATCHETS	HANDLE	<b>ELECTRIC KIT</b>	ACTUATORS	<b>CONTROL SYSTEM</b>	BUILT IN SWITCHES	CONTROL PLATES
CARTER	FINISHES	SEAT AND FOOTREST FRAME	KINETIC	PLUGS & CABLE EXTENSIONS	POWER SUPPLY & BATTERY PACKS	TOUCH SENSOR	WIRED/ WIRELESS REMOTES	SMARTPHONE CONTROL SYSTEM
ARMREST KIT	DORSAL	ARMREST		CONNECTOR				

# LEVANTE

CLASSIC STD LIFT EXTENDED M2

Code PL07079-XX-GP

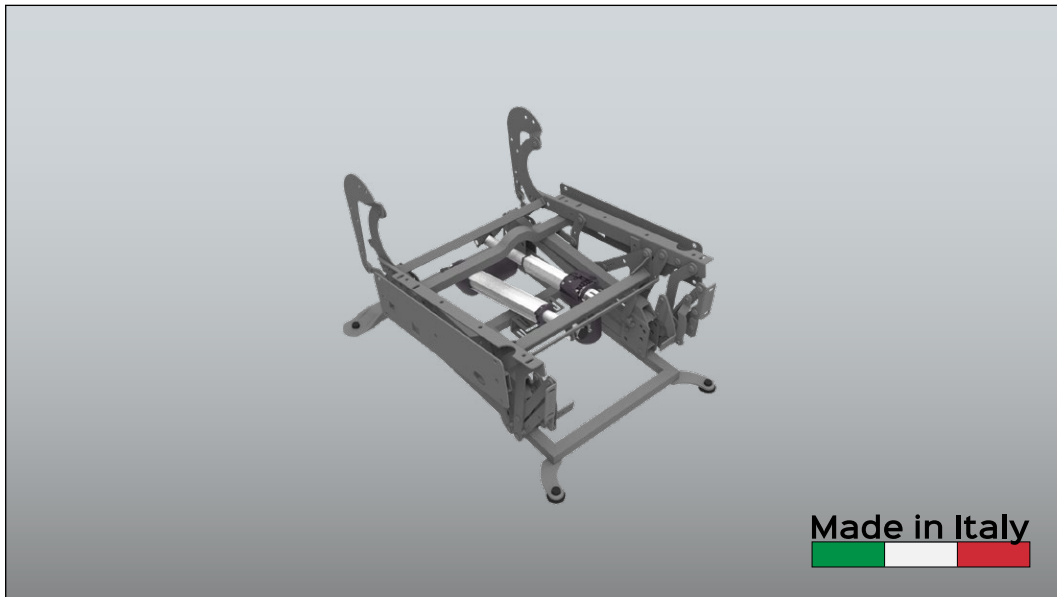

Made in Italy

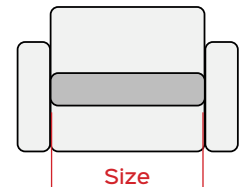

Standard sizes (mm)
520

Motorized	26kg +/- 1kg	Armchair	MAX 170kg 380lbs Maximum lifting capacity	Cycles: 30.000	2 YEARS Mechanism 2 YEARS Actuator Warranty
-----------	--------------	----------	--	----------------	--

Positions:

Closed

TV

Full Relax

Lift

**Benefit:** The KEYMOTION mechanisms are built entirely in Italy, from the raw material, to the processing, up to the final assembly and testing. The products are carefully checked before being shipped. Designed to ensure high lifting performance and comfort, facilitating the everyday life of the most needy user. This mechanism is equipped with a flap that increases the extension of the footboard (improving comfort), in TV and Full

Relax positions. Two motors regulate the different positions: closed, TV, full relax and lift. The first actuator, in addition to bringing the padded in position Lift, extends the footboard by doing a slight tilting action to the seat and backrest; the second actuator instead reclines the backrest until you reach the Full Relax position. The lift system lifts the padded (from closed position) allowing the person to stand upright. The mechanism is equipped with a base.

## Optional

SOME ACCESSORIES	TROLLEY KIT	HEADREST & RATCHETS	HANDLE	ELECTRIC KIT	ACTUATORS	CONTROL SYSTEM	BUILT IN SWITCHES	CONTROL PLATES			
	CARTER	FINISHES	SEAT AND FOOTREST FRAME		ARMREST		PLUGS & CABLE EXTENSIONS	POWER SUPPLY & BATTERY PACKS	TOUCH SENSOR	WIRED/ WIRELESS REMOTES	SMARTPHONE CONTROL SYSTEM
	ARMREST KIT	DORSAL	KINETIC		CONNECTOR						

# LEVANTE

BED CLASSIC VERTICAL LIFT M2

Code PL07088-XX-GP

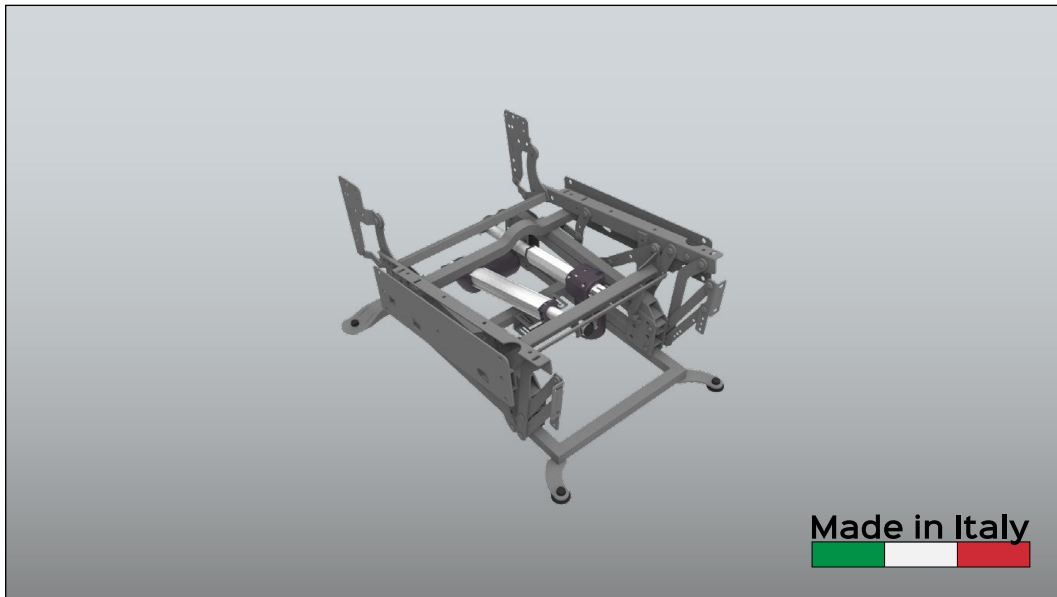

Standard sizes (mm)
520

 Motorized	 25 kg +/- 1kg	 Armchair	 MAX 170kg 380lbs Maximum lifting capacity	 Cycles:30.000	 2YEARS Mechanism 2YEARS Actuator Warranty
---------------	-------------------	--------------	--	-------------------	---

Positions:

Closed

TV

Bed

Lift

**Benefit:** The KEYMOTION mechanisms are built entirely in Italy, from the raw material, to the processing, up to the final assembly and testing. The products are carefully checked before being shipped. This mechanism is designed to ensure high lifting performance and comfort, facilitating the everyday life of the most needy user. Two motors regulate the different positions: closed, TV, bed and lift. The first actuator, in addition to bringing the padded in position Lift,

extends the footboard by doing a slight tilting action to the seat and backrest; the second actuator instead reclines the backrest until you reach the Bed position. The vertical-lift system raises the padding without rotation for the first 10 cm, allowing the person to adapt to intermediate heights before standing. Finally, the Bed backrest increases the comfort in the open position with an inclination of as much as 22° more than the standard version. The mechanism is equipped with a base.

## Optional

SOME ACCESSORIES	 TROLLEY KIT	 HEADREST & RATCHETS	 HANDLE	ELECTRIC KIT	 ACTUATORS	CONTROL SYSTEM	 BUILT IN SWITCHES	 CONTROL PLATES
 CARTER	 FINISHES	 DOUBLE FOOTBOARD	 KINETIC	 PLUGS & CABLE EXTENSIONS	 POWER SUPPLY & BATTERY PACKS	 TOUCH SENSOR	 WIRED/ WIRELESS REMOTES	 SMARTPHONE CONTROL SYSTEM
 ARMREST KIT	 DORSAL	 SEAT AND FOOTREST FRAME	 ARMREST	 CONNECTOR				

# LEVANTE

## CLASSIC STD LIFT M1

Code PL07091-XX-GP

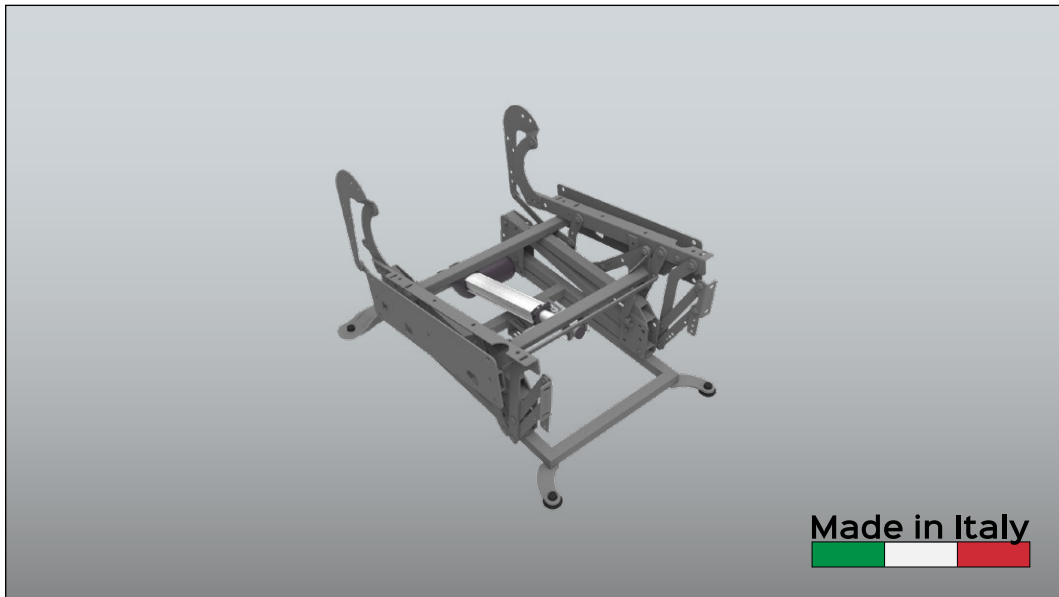

Made in Italy

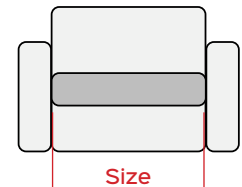

Standard sizes (mm)

520

Motorized	22 kg +/- 1kg	Armchair	MAX 170kg 380lbs Maximum lifting capacity	Cycles: 30.000	2 YEARS Mechanism 2 YEARS Actuator Warranty
-----------	---------------	----------	--	----------------	---

Positions:

Closed

Full Relax

Lift

**Benefit:** The KEYMOTION mechanisms are built entirely in Italy, from the raw material, to the processing, up to the final assembly and testing. The products are carefully checked before being shipped. This mechanism is designed to ensure high lifting performance and comfort, facilitating the everyday life of the most needy user. The actuator adjusts the

different positions: closed, full relax and lift. The latter extends the footboard by doing a slight tilting action to the seat and backrest. The footboard and backrest will then open, in a synchronized way. The lift system lifts the padded (from Closed position) allowing the person to stand upright. The mechanism is equipped with a base.

### Optional

SOME ACCESSORIES	TROLLEY KIT	HEADREST & RATCHETS	HANDLE	ELECTRIC KIT	ACTUATORS	CONTROL SYSTEM	BUILT IN SWITCHES	CONTROL PLATES		
	CARTER	FINISHES	DOUBLE FOOTBOARD		ARMREST		PLUGS & CABLE EXTENSIONS	POWER SUPPLY & BATTERY PACKS	TOUCH SENSOR	WIRED/WIRELESS REMOTES
	ARMREST KIT	DORSAL	SEAT AND FOOTREST FRAME		KINETIC		CONNECTOR	SMARTPHONE CONTROL SYSTEM		



# LEVANTE

## CLASSIC STD LIFT M2

Code *PL07092-XX-GP*

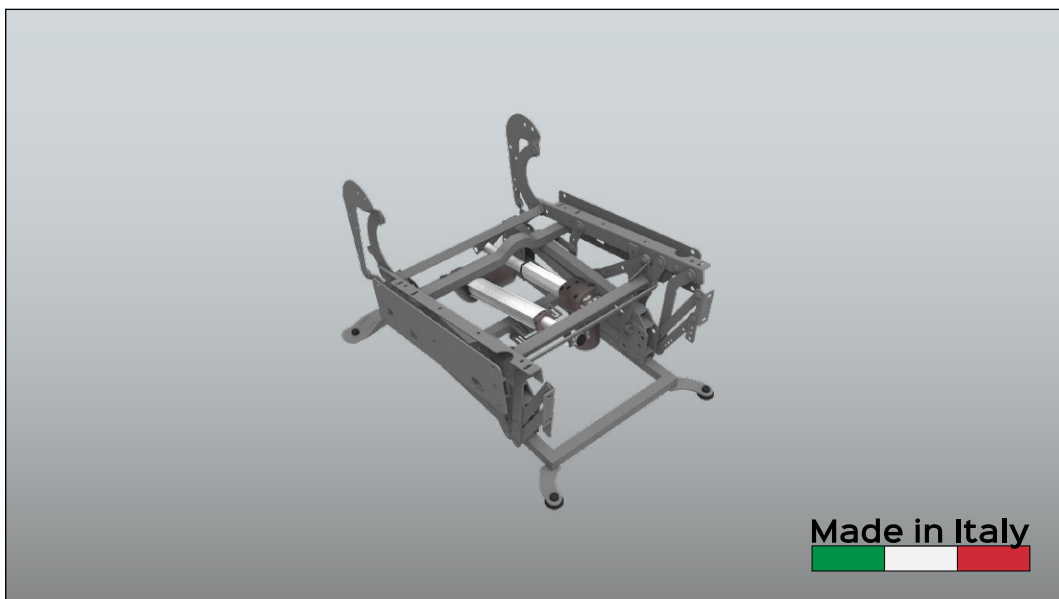

Made in Italy

Standard sizes (mm)

**520**

Motorized	25kg +/- 1kg	Armchair	<b>MAX</b> 170kg 380lbs Maximum lifting capacity	Cycles: 30.000	<b>2 YEARS</b> Mechanism <b>2 YEARS</b> Actuator Warranty
-----------	--------------	----------	---	----------------	---

Positions:

Closed	TV	Full Relax	Lift

**Benefit:** The KEYMOTION mechanisms are built entirely in Italy, from the raw material, to the processing, up to the final assembly and testing. The products are carefully checked before being shipped. This mechanism is designed to ensure high lifting performance and comfort, facilitating the everyday life of the most needy user. Two motors regulate the different positions: closed, TV, full relax and lift. The first actuator, in

addition to bringing the padded in position Lift, extends the footboard by doing a slight tilting action to the seat and backrest; the second actuator instead reclines the backrest until you reach the Full Relax position. The lift system lifts the padded (from closed position) allowing the person to stand upright. The mechanism is equipped with a base.

### Optional

<b>SOME ACCESSORIES</b>	TROLLEY KIT	HEADREST & RATCHETS	HANDLE	<b>ELECTRIC KIT</b>	ACTUATORS	<b>CONTROL SYSTEM</b>	BUILT IN SWITCHES	CONTROL PLATES
CARTER	FINISHES	DOUBLE FOOTBOARD	KINETIC	PLUGS & CABLE EXTENSIONS	POWER SUPPLY & BATTERY PACKS	TOUCH SENSOR	WIRED/WIRELESS REMOTES	SMARTPHONE CONTROL SYSTEM
ARMREST KIT	DORSAL	SEAT AND FOOTREST FRAME	ARMREST	CONNECTOR				

# LEVANTE

MINUS CLASSIC STD LIFT M2

Code PL07093-XX-GP

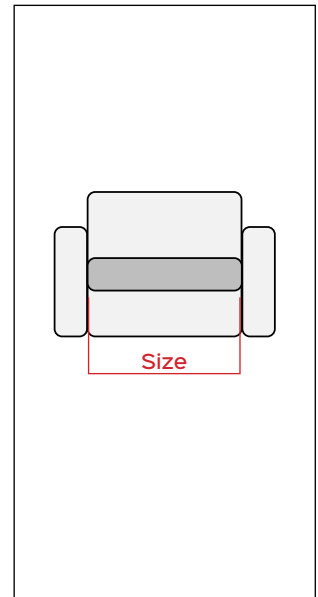
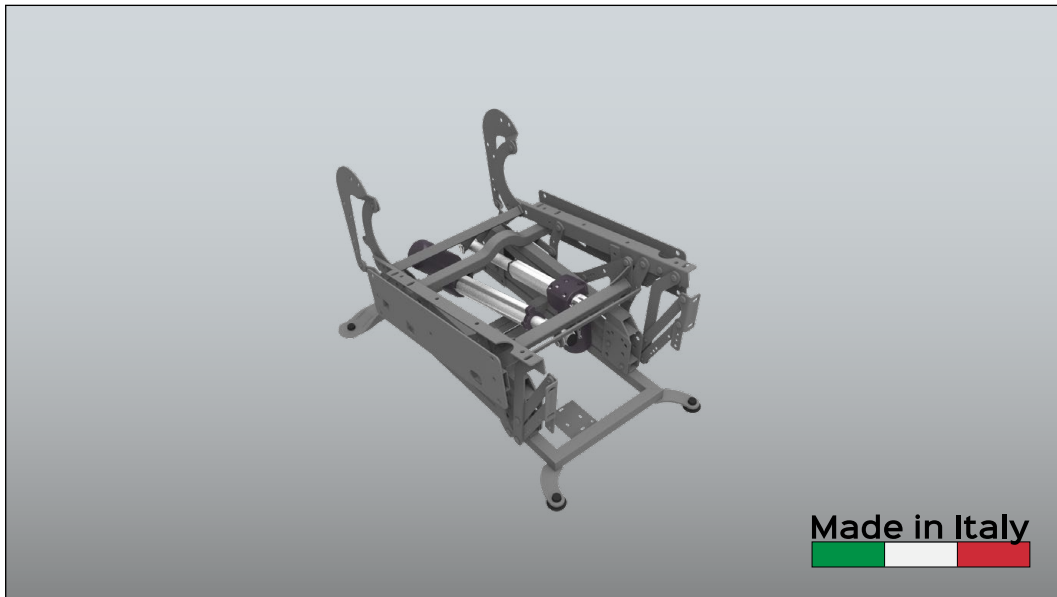

Motorized	23 kg +/-1kg	Armchair	MAX 170kg 380lbs Maximum lifting capacity	Cycles:30.000	2YEARS Mechanism 2YEARS Actuator Warranty
-----------	--------------	----------	--	---------------	---

Standard sizes (mm)
450

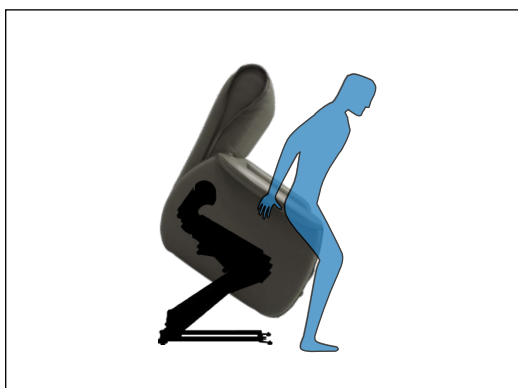

Positions:

Closed	TV	Full Relax	Lift

**Benefit:** The KEYMOTION mechanisms are built entirely in Italy, from the raw material, to the processing, up to the final assembly and testing. The products are carefully checked before being shipped. The mechanics of this chair lift has been designed specifically to ensure maximum comfort. The reduced dimensions and the narrower seat, characteristics of the "MINUS" mechanism, make it suitable for smaller spaces.

Two motors regulate the different positions: closed, TV, fullrelax and lift. The first actuator, in addition to bringing the padded in position Lift, extends the footboard by doing a slight tilting action to the seat and backrest; the second actuator instead reclines the backrest until you reach the Full Relax position. The lift system lifts the padded (from closed position) allowing the person to stand upright. The mechanism is equipped with a base.

## Optional

<b>SOME ACCESSORIES</b>	TROLLEY KIT	HEADREST & RATCHETS	<b>ELECTRIC KIT</b>	ACTUATORS	<b>CONTROL SYSTEM</b>	BUILT IN SWITCHES	CONTROL PLATES
CARTER	FINISHES	DOUBLE FOOTBOARD	PLUGS & CABLE EXTENSIONS	POWER SUPPLY & BATTERY PACKS	TOUCH SENSOR	WIRED/ WIRELESS REMOTES	SMARTPHONE CONTROL SYSTEM
ARMREST KIT	HANDLE	ARMREST	CONNECTOR				

# LEVANTE CLASSIC STD LIFT M2 WITH MASSAGING BACKREST HELYCOS

Code PL07358-XX-GP

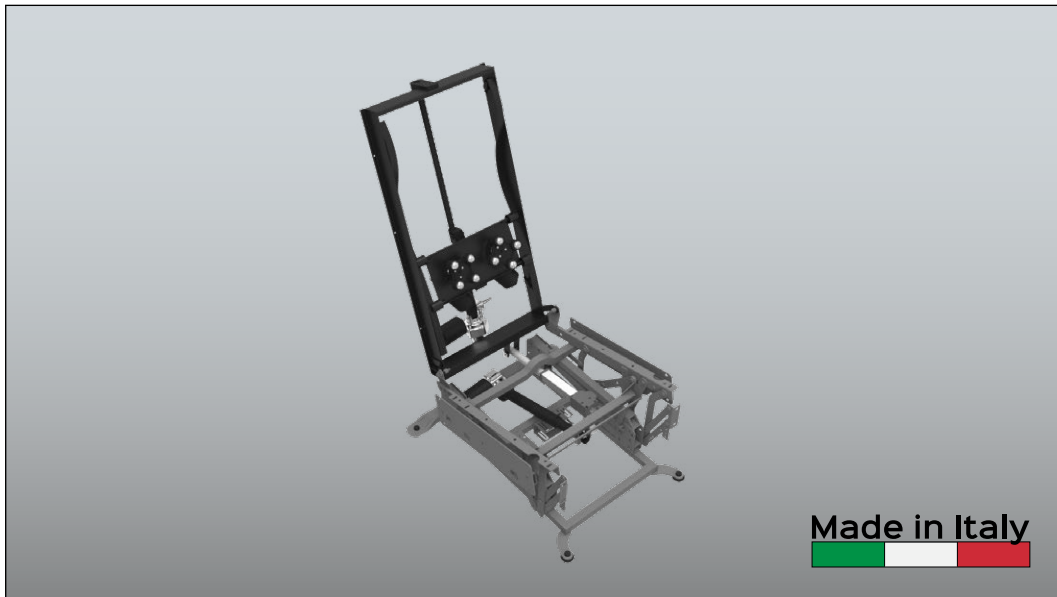

Standard sizes (mm)

**520**

Motorized	35,5kg +/- 1kg	Armchair	<b>MAX 170kg 380lbs</b> Maximum lifting capacity	Cycles:30.000	<b>2YEARS Mechanism 2YEARS Actuator</b> Warranty
-----------	----------------	----------	---	---------------	---



Positions:



Closed



TV



Full Relax



Lift

**Benefit:** The KEYMOTION mechanisms are built entirely in Italy. This mechanism is designed to ensure high lifting performance and comfort, facilitating the everyday life of the most needy user. Two motors regulate the different positions: closed, TV, full relax and lift. The first actuator, in addition to bringing the padded in position Lift, extends the footboard by doing a slight tilting action to the seat and backrest; the second actuator instead reclines the backrest

until you reach the Full Relax position. The vertical-lift system raises the lift system lifts the padded (from closed position) allowing the person to stand upright. The combination with the Helycos backrest elevates the product to the highest level of comfort. In combination with the movements of the seat mechanism in fact you can enjoy the massage action, relaxing, in the position considered most appropriate, giving a pleasant feeling of relaxation. The mechanism is equipped with a base.

## Optional

SOME ACCESSORIES	TROLLEY KIT	SEAT AND FOOTREST FRAME	ELECTRIC KIT	ACTUATORS	CONTROL SYSTEM	BUILT IN SWITCHES	CONTROL PLATES		
	CARTER	FINISHES		DOUBLE FOOTBOARD		PLUGS & CABLE EXTENSIONS	POWER SUPPLY & BATTERY PACKS	TOUCH SENSOR	WIRED/WIRELESS REMOTES
	ARMREST KIT	HANDLE		ARMREST		CONNECTOR	SMARTPHONE CONTROL SYSTEM		

# LEVANTE

CLASSIC STD 630 LIFT M2

Code PL07550-XX-GP

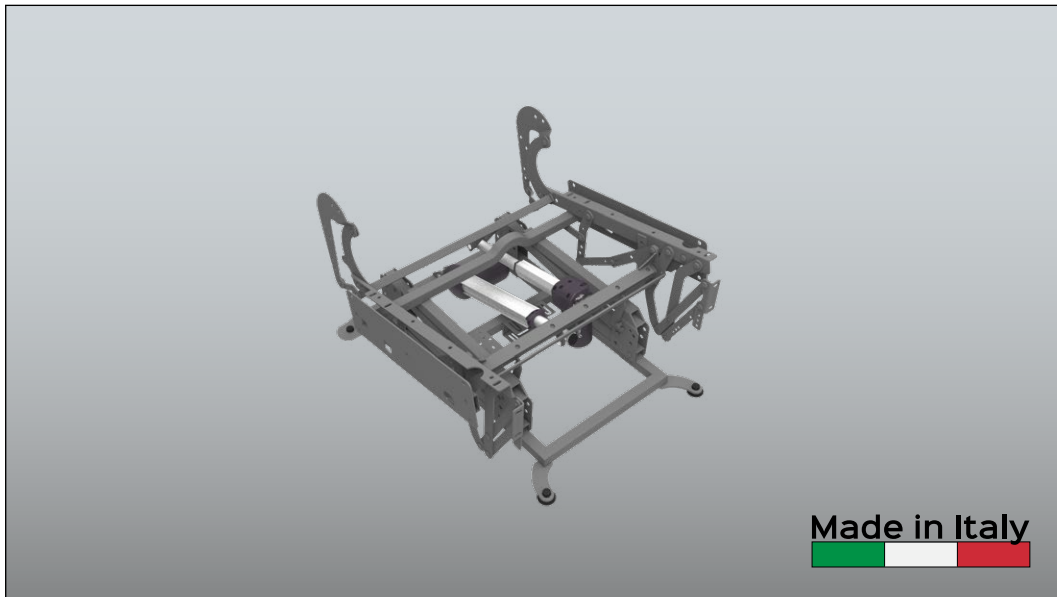

Made in Italy

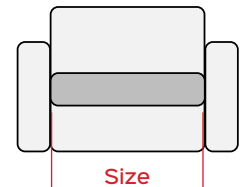

Standard sizes (mm)
<b>630</b>

Motorized	25kg +/- 1kg	Armchair	<b>MAX</b> 170kg 380lbs Maximum lifting capacity	Cycles: 30.000	<b>2 YEARS</b> Mechanism <b>2 YEARS</b> Actuator Warranty
-----------	--------------	----------	---	----------------	---

Positions:

Closed

TV

Full Relax

Lift

**Benefit:** The KEYMOTION mechanisms are built entirely in Italy, from the raw material, to the processing, up to the final assembly and testing. The products are carefully checked before being shipped. This mechanism is designed to ensure high lifting performance and comfort, facilitating the everyday life of the most needy user. Two motors regulate the different positions: closed, TV, full relax and lift. The first actuator, in

addition to bringing the padded in position Lift, extends the footboard by doing a slight tilting action to the seat and backrest; the second actuator instead reclines the backrest until you reach the Full Relax position. The lift system lifts the padded (from closed position) allowing the person to stand upright. The mechanism is equipped with a base.

## Optional

SOME ACCESSORIES		TROLLEY KIT	HEADREST & RATCHETS	HANDLE	ELECTRIC KIT		ACTUATORS	CONTROL SYSTEM		BUILT IN SWITCHES	CONTROL PLATES
CARTER	FINISHES	DOUBLE FOOTBOARD	ARMREST	PLUGS & CABLE EXTENSIONS	POWER SUPPLY & BATTERY PACKS	TOUCH SENSOR	WIRED/WIRELESS REMOTES	SMARTPHONE CONTROL SYSTEM			
ARMREST KIT	DORSAL			CONNECTOR							

# LEVANTE

MACY CLASSIC STD LIFT EXTENDED M3

Code PL07551-XX-GP

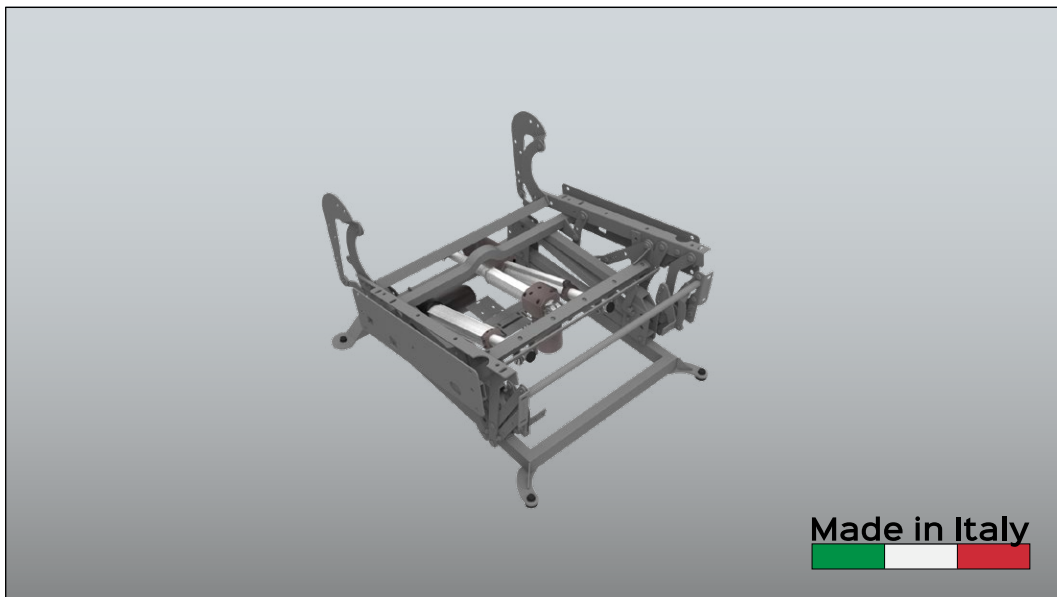

Made in Italy

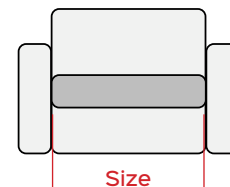

Standard sizes (mm)

630

Motorized	31kg+/-1kg	Armchair	MAX 280kg 620lbs Maximum lifting capacity	Cycles:30.000	2YEARS Mechanism 2YEARS Actuator Warranty
-----------	------------	----------	--	---------------	---



Positions:



**Benefit:** The KEYMOTION mechanisms are built entirely in Italy, from the raw material, to the processing, up to the final assembly and testing. The products are carefully checked before being shipped. This mechanism has been designed specifically to ensure maximum comfort, is equipped with a flap that increases the extension of the footboard improving the performance in the TV position and full relaxation. Three actuators adjust the different positions, ensuring infinite positions, from closed to TV, from full relaxation to the lift.

The first actuator extends the footboard and plays a light tilting action of the seat and back; the second actuator reclines the backrest reaching the position of maximum comfort called full relax. Both movements are independent of each other, to allow any postural position. The third actuator was inserted in parallel to the first, to increase the maximum lifting capacity. The lift system lifts the padded (from Closed position) allowing the person to stand upright. The mechanism is equipped with a base.

## Optional

<b>SOME ACCESSORIES</b>	TROLLEY KIT	HEADREST & RATCHETS	<b>ELECTRIC KIT</b>	ACTUATORS	<b>CONTROL SYSTEM</b>	BUILT IN SWITCHES	CONTROL PLATES
CARTER	FINISHES	HANDLE	PLUGS & CABLE EXTENSIONS	POWER SUPPLY & BATTERY PACKS	TOUCH SENSOR	WIRED/ WIRELESS REMOTES	SMARTPHONE CONTROL SYSTEM
ARMREST KIT	DORSAL	ARMREST	CONNECTOR				

**Keymotion by motionitalia** Design and quality Made in Italy

Business Unit Lucrezia: Via Enzo Ferrari 7, 61030 Lucrezia (PU) Tel. +39 0721 170 74 54 [www.key-motion.it](http://www.key-motion.it)

Headquarters: via Navicella 26, 47122 Forlì (FC) Tel.+39 0543 774768 Fax.+39 0543 798409 [www.motionitalia.com](http://www.motionitalia.com) [info@motionitalia.com](mailto:info@motionitalia.com)

The producer reserves the right to modify, at any moment and without notice, the technical specification of its products

# LEVANTE

BED KD AVANTGARDE VERTICAL LIFT M2

Code PR07965-XX-GP

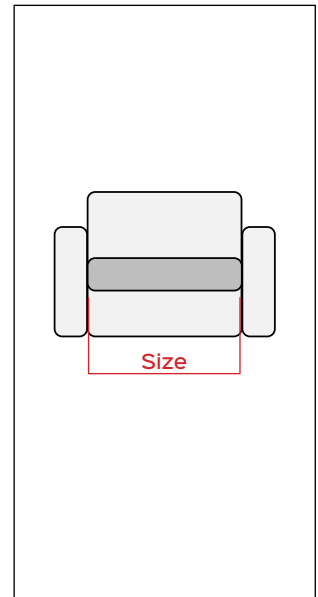
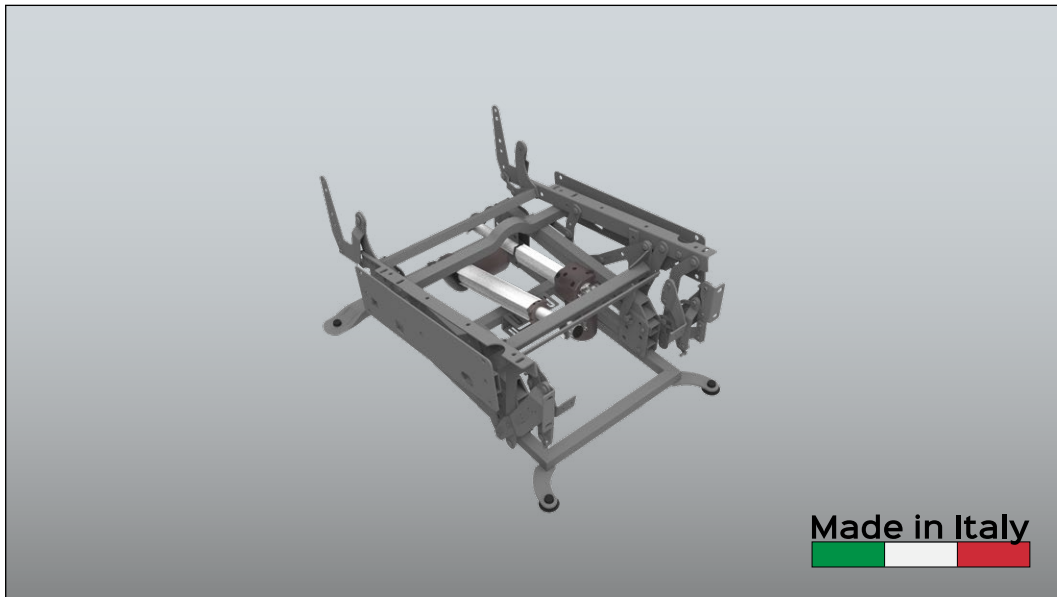

Motorized	25 kg +/- 1kg	Armchair	MAX 170kg 380lbs Maximum lifting capacity	Cycles: 30.000	2 YEARS Mechanism 2 YEARS Actuator Warranty
-----------	---------------	----------	--	----------------	--

Standard sizes (mm)
520

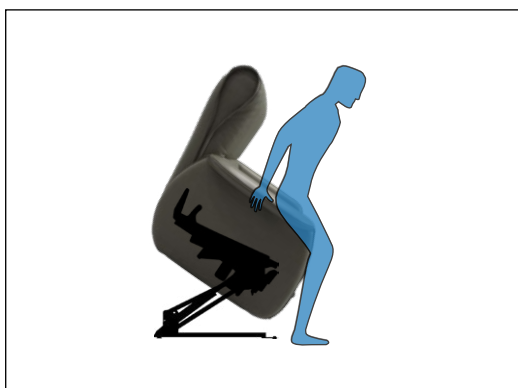

Positions:

Closed	TV	Bed	Lift

**Benefit:** The KEYMOTION mechanisms are built entirely in Italy, from the raw material, to the processing, up to the final assembly and testing. The products are carefully checked before being shipped. This mechanism is designed to ensure high lifting performance and comfort, facilitating the everyday life of the most needy user. The vertical-lift system raises the padding without rotation for the first 10cm, allowing the person to adapt to intermediate heights

before standing. Two motors regulate the different positions: closed, TV, fullrelax and lift. The first actuator extends the footboard and performs a slight tilting action of the seat and backrest; the second actuator instead reclines the backrest until it reaches the position of maximum extension. Finally, the BED backrest increases the comfort in the open position with an inclination of as much as 22° more than the standard version. The mechanism is equipped with a base.

## Optional

<b>SOME ACCESSORIES</b>	TROLLEY KIT	HEADREST & RATCHETS	HANDLE	<b>ELECTRIC KIT</b>	ACTUATORS	<b>CONTROL SYSTEM</b>	BUILT IN SWITCHES	CONTROL PLATES
ARMREST KIT	FINISHES	SEAT AND FOOTREST FRAME	KINETIC	PLUGS & CABLE EXTENSIONS	POWER SUPPLY & BATTERY PACKS	TOUCH SENSOR	WIRED/ WIRELESS REMOTES	SMARTPHONE CONTROL SYSTEM
DORSAL	KD	ARMREST		CONNECTOR				

# LEVANTE

MACY LIFT CLASSIC AVANTGARDE M3

Code PR08255-XX-GP

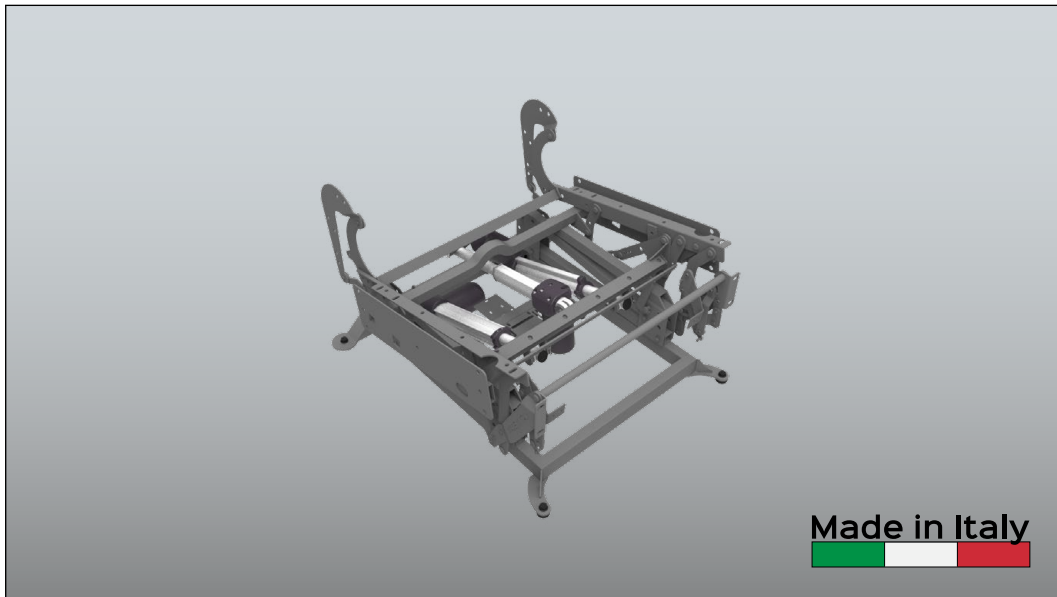

Made in Italy

Standard sizes (mm)
630

Motorized	31kg+/-1kg	Armchair	MAX 280kg 620lbs Maximum lifting capacity	Cycles:30.000	2YEARS Mechanism 2YEARS Actuator Warranty
-----------	------------	----------	--	---------------	---

Positions:

Closed

TV

Full Relax

Lift

**Benefit:** The KEYMOTION mechanisms are built entirely in Italy, from the raw material, to the processing, up to the final assembly and testing. The products are carefully checked before being shipped. This mechanism is designed to ensure high lifting performance and comfort, facilitating the everyday life of the most needy user. Three motors regulate the different positions: closed, TV, full relax and lift. The first actuator, in

addition to bringing the padded in position Lift, extends the footboard by doing a slight tilting action to the seat and backrest; the second actuator instead reclines the backrest until you reach the Full Relax position. The third actuator reclines the backrest until it reaches the Full Relax position. The lift system lifts the padded (from closed position) allowing the person to stand upright. The mechanism is equipped with a base.

## Optional

SOME ACCESSORIES	TROLLEY KIT	HEADREST & RATCHETS	ELECTRIC KIT	ACTUATORS	CONTROL SYSTEM	BUILT IN SWITCHES	CONTROL PLATES		
	CARTER	FINISHES		HANDLE		PLUGS & CABLE EXTENSIONS	POWER SUPPLY & BATTERY PACKS	TOUCH SENSOR	WIRED/WIRELESS REMOTES
	ARMREST KIT	DORSAL		ARMREST		CONNECTOR	SMARTPHONE CONTROL SYSTEM		

# LEVANTE

MACY BED KD AVANTGARDE LIFT M3

Code PR08465-XX-GP

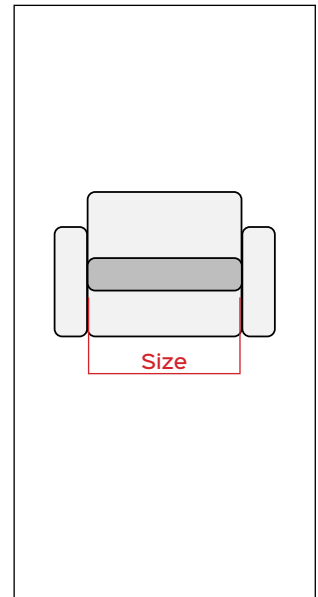
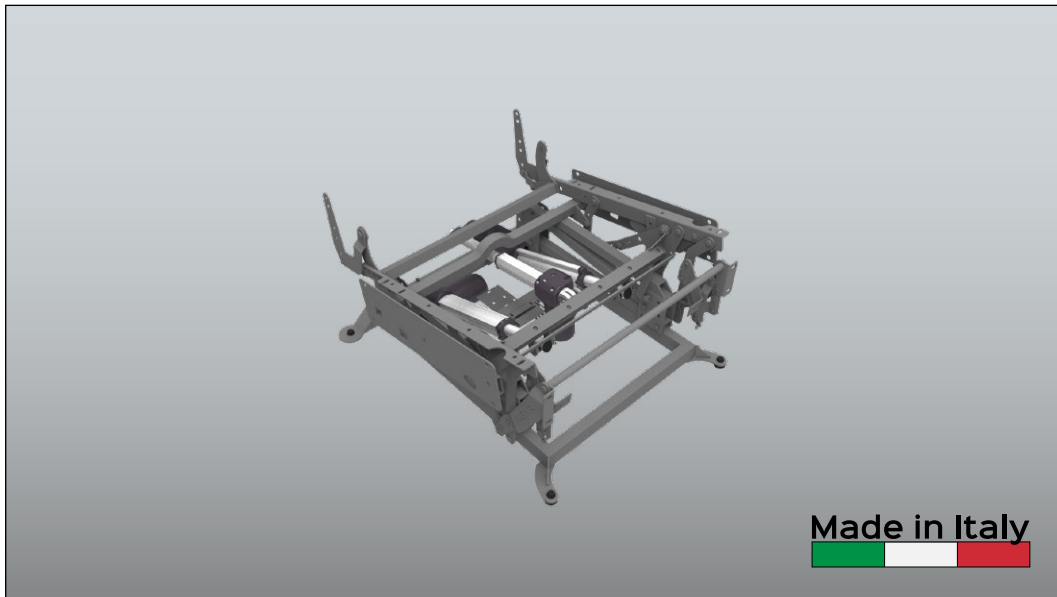

Motorized	31kg+/-1kg	Armchair	MAX 280kg 620lbs Maximum lifting capacity	Cycles:30.000	2YEARS Mechanism 2YEARS Actuator Warranty
-----------	------------	----------	--	---------------	---

Standard sizes (mm)
630

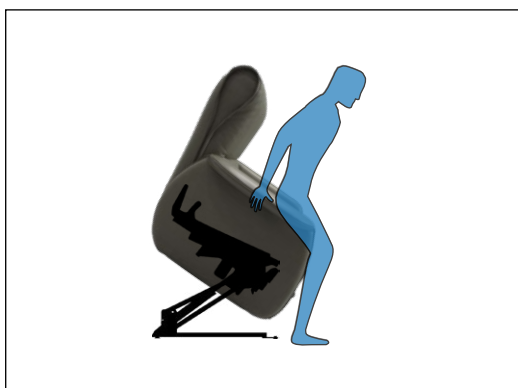

Positions:

Closed	TV	Bed	Lift

**Benefit:** The KEYMOTION mechanisms are built entirely in Italy, from the raw material, to the processing, up to the final assembly and testing. The products are carefully checked before being shipped. This mechanism is designed to ensure high lifting performance and comfort, facilitating the everyday life of the most needy user. Three motors regulate the different positions: Closed, TV, Bed and Lift. The first actuator and the

second, extend the footboard by doing a slight tilting action to the seat and backrest, finally lift the padded up to the Lift position. The third actuator reclines the backrest until it reaches the Bed position. Finally, the BED backrest increases the comfort in the open position with an inclination of as much as 22° more than the standard version. The mechanism is equipped with a base.

## Optional

<b>SOME ACCESSORIES</b>	TROLLEY KIT	HEADREST & RATCHETS	<b>ELECTRIC KIT</b>	ACTUATORS	<b>CONTROL SYSTEM</b>	BUILT IN SWITCHES	CONTROL PLATES
ARMREST KIT	FINISHES	HANDLE	PLUGS & CABLE EXTENSIONS	POWER SUPPLY & BATTERY PACKS	TOUCH SENSOR	WIRED/ WIRELESS REMOTES	SMARTPHONE CONTROL SYSTEM
DORSAL	KD	ARMREST	CONNECTOR				